

MOSAIK® is the well-proven triple purpose cask for all kinds of ILW that requires higher shielding. The concept has been confirmed with more than 9,000 casks supplied.

- Easy handling by forklift or crane with flexible customized handling equipment
- Suitable for various types of waste and optionally equipped with connections for treatment plants
- Perfectly suited for direct underwater loading – no additional shielding required
- Can be fitted with various lead inserts to increase shielding capacities

### DESCRIPTION

GNS develops, produces and markets MOSAIK® casks made of ductile cast iron for Intermediate Level Waste occurring during the operation and shutting down of nuclear facilities. The MOSAIK® casks are designed as transport and storage casks for e.g. core components and for conditioning of ion exchange resins or evaporator concentrate. As the casks are equipped with the respective necessary connections, waste can be directly conditioned inside MOSAIK® casks with methods and facilities developed by GNS so as to be suitable for final disposal.

To accommodate various kinds of waste, the cask types have different volumes, wall thicknesses or lid systems and may have additional lead shielding, extraction systems and filter systems. In the recycling process, low-level radioactive metal scrap may be used for the casting of MOSAIK® containers. For transport in accordance with ADR\* MOSAIK® casks are available with Type B(U) approval certificate or casks which are used as containers for IP-2 packages.

\* European accord for international transport of dangerous goods on the road (Accord Européen relatif au transport international des marchandises dangereuses en route)

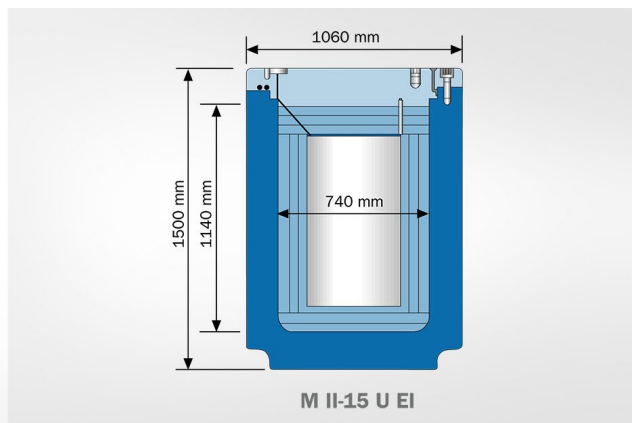
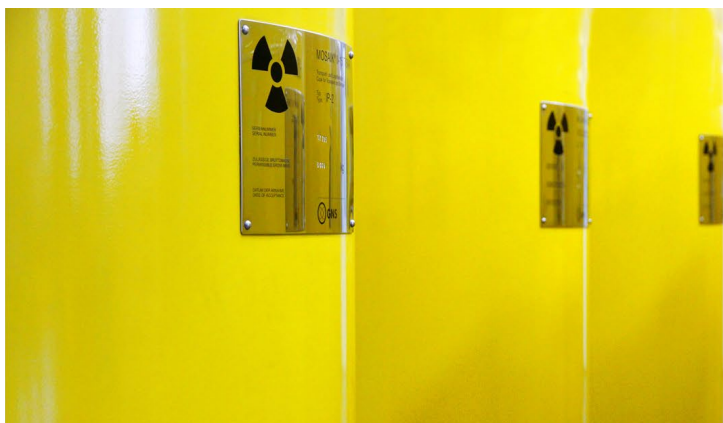

## TECHNICAL DATA

MOSAIK®	M II-15 EI	M II-15 U EI*
	Type B (U) or IP2	
Outer height (mm)	1,500	
Outer diameter (mm)	1,060	
Internal height max. (mm)	1,140	
Internal diameter (mm)	740	
Wall thickness (mm)	160	
Lead shielding min. – max. (mm)	0 – 120	
Empty weight approx. (kg)	5,730 – 9,230	
Volume max. ( dm <sup>3</sup> )	165 – 490	
Options	Baffle plate Suction device	

\* Unterwater loading

## HANDLING

Equipment for handling of MOSAIK® containers in dry conditions and for loading in the reactor pool.

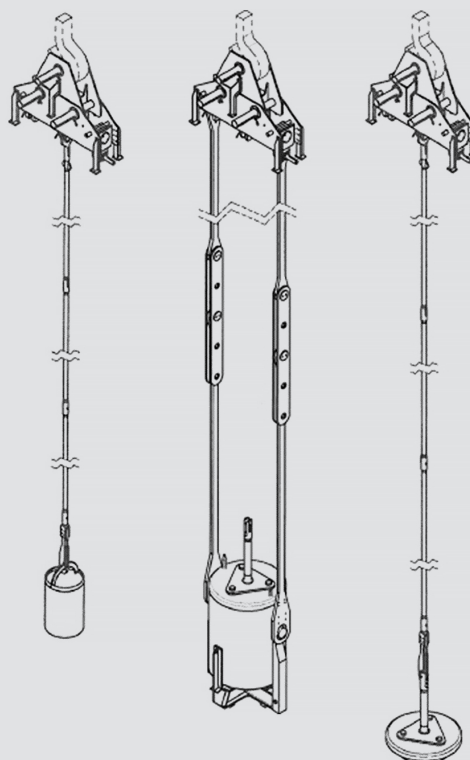

Design and manufacture of the handling equipment for MOSAIK® containers II-15 U EI will be in coordination with the local interfaces.