

# CASTOR® V/52

Transport and Storage Cask  
for Spent Fuel (BWR)

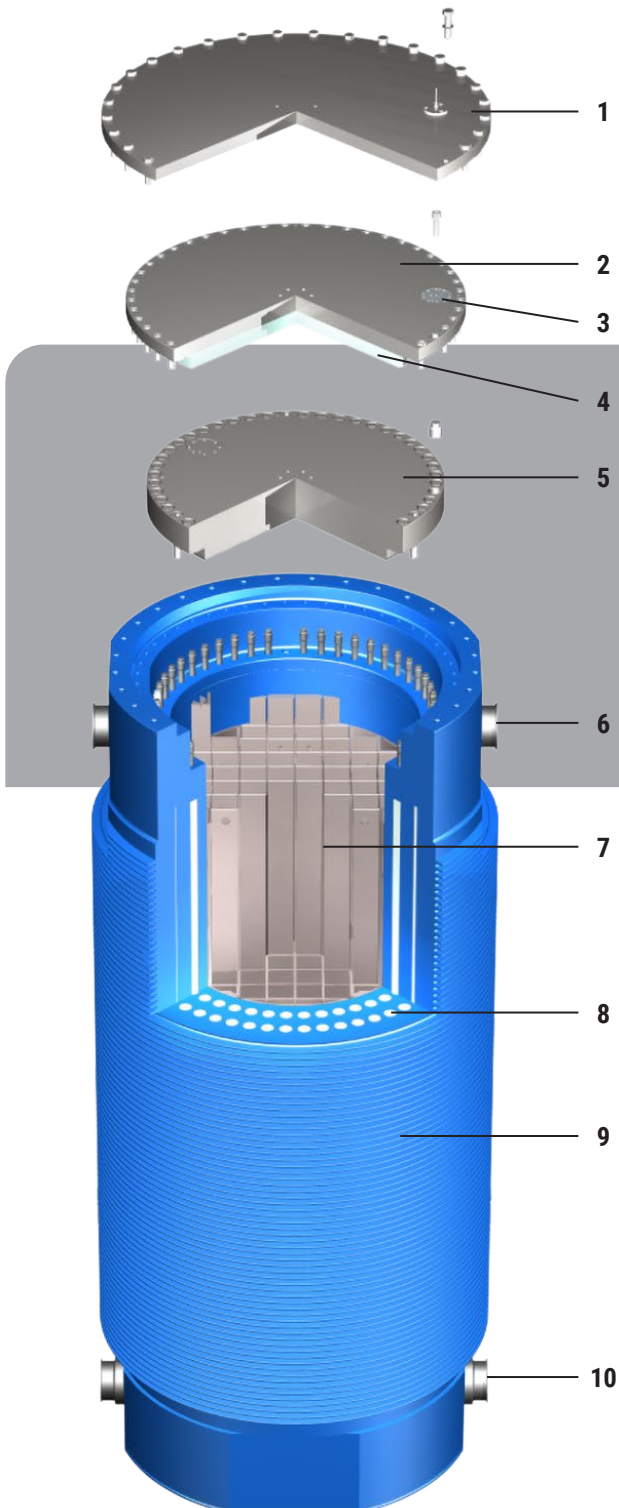

## DESCRIPTION

The CASTOR® V/52 cask is designed for the transport and storage of spent fuel assemblies from boiling water reactors (BWR).

The cask consists of a monolithic body [9] made of ductile cast iron, a basket [7] for accommodating the fuel assemblies and a double-lid system (primary [5], and secondary lid [2] arranged one above the other) as well as a protection plate [1].

On the outside wall, radial cooling fins are machined to improve the passive heat dissipation. The double-lid system made of stainless steel is tightly bolted to the cask body guaranteeing a safe long-term containment of the fuel assemblies. During interim storage the lid system consisting of the two barriers is permanently being monitored for leak-tightness. Monitoring is performed by a pressure switch [3] which is integrated in the secondary lid [2].

For neutron moderation, axial boreholes are drilled into the cask wall and filled with polyethylene moderator rods [8]. In addition, there are plates of polyethylene [4] at the bottom end and on the underside of the secondary lid.

At the bottom and lid end of the cask body, one pair of trunnions [6, 10] each is bolted for attachment of handling equipment. For transport on public routes the cask can be equipped with shock absorbers.

**Excellence** for Nuclear.

GNS Gesellschaft für Nuklear-Service mbH · Frohnhauser Str. 67 · 45127 Essen · Germany  
Phone +49 201 109-0 · info@gns.de · www.gns.de

# CASTOR® V/52

Transport and Storage Cask  
for Spent Fuel (BWR)



## LICENSES

The CASTOR® V/52 has the necessary licenses for transport, long-term interim storage as well as for handling in nuclear facilities.

The design complies with the international regulations from the IAEA (International Atomic Energy Agency) for type B(U)F package designs for the transport on public transport ways (roads, rail, shipping).

## REFERENCES

Already more than 720 CASTOR® V-casks have been loaded and stored so far.

More than 240 CASTOR® V/52-casks have been loaded in the German BWR sites in Brunsbüttel, Gundremmingen, Isar, Krümmel and Philippsburg and are stored in their on-site interim storage facilities as well as in the interim storage facility at Ahaus (GER).

Further CASTOR® V/52-casks will be delivered to Switzerland in the next few years. The CASTOR® V/52 (CH) has a transport licence and type approval for storage in Switzerland.

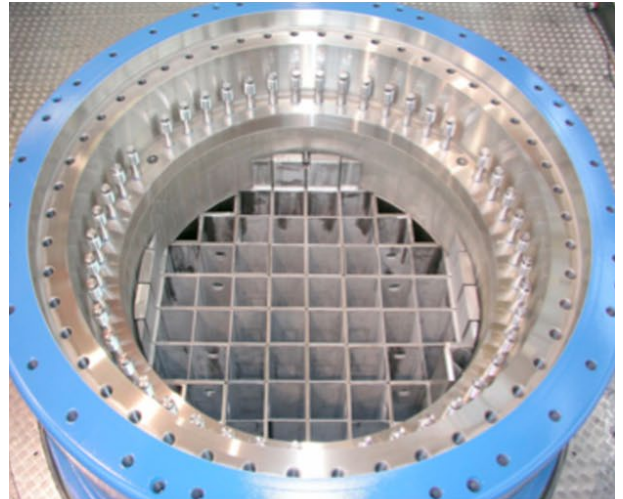

## TECHNICAL DATA

### Cask Contents

Up to 52 spent fuel assemblies from BWR  
(total length max. 4,485 mm, edge length max. 141 mm)

Total thermal power	40 kW
Total activity	1,730 PBq

### Dimensions and Weight in the Storage Configuration

Overall height	553 cm
Outer diameter	244 cm
Cavity height	455 cm
Cavity diameter	148 cm
Cask weight empty	≈ 105 t

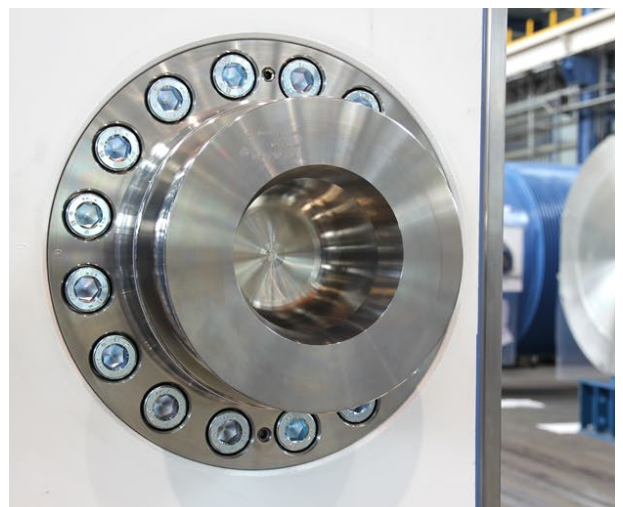

**Excellence** for Nuclear.

GNS Gesellschaft für Nuklear-Service mbH · Frohnhauser Str. 67 · 45127 Essen · Germany  
Phone +49 201 109-0 · info@gns.de · www.gns.de